

**AMIGA COMPUTER
MODEL 1000**

**ASSEMBLY LEVEL REPAIR
PN 314038-01**

Commodore-Amiga, Inc.

1200 Wilson Drive, West Chester, Pennsylvania 19380 U.S.A.

Commodore-Amiga Inc. makes no expressed or implied warranties with regard to the information contained herein. The information is made available solely on an as is basis, and the entire risk as to quality and accuracy is with the user. Commodore-Amiga Inc. shall not be liable for any consequential or incidental damages in connection with the use of the information contained herein. The listing of any available replacement part herein does not constitute in any case a recommendation, warranty or guaranty as to quality or suitability of such replacement part. Reproduction or use without expressed permission, of editorial or pictorial content, in any matter is prohibited.

This manual contains copyrighted and proprietary information. No part of this publication may be reproduced, stored in a retrieval system, or transmitted in any form or by any means, electronic, mechanical, photocopying, recording or otherwise, without the prior written permission of Commodore-Amiga Inc.

Copyright © 1985 by Commodore-Amiga Inc.
All rights reserved.

INTRODUCTION

The AMIGA 1000 Assembly Level Repair module is divided into 3 sections:

- Section 1: Set-up & Test**
- Section 2: Computer Disassembly**
- Section 3: Computer Assembly**

Section 1 is intended to instruct the technician in proper set-up and diagnosis of problems to the ASSEMBLY LEVEL. Assembly level may be defined as those portions of the unit that may be easily disassembled and replaced without involvement with chip/component repair.

Section 2 is step-by-step illustration of how to remove the various assemblies from the unit. An overview of the assemblies is given on page 1-1.

Section 3 is a guide to re-assembling the computer after a repair is completed.

WARRANTY REPAIR is to be accomplished at the ASSEMBLY LEVEL. That is, as it is described within these 3 sections. Out-of-warranty repair at the component (chip) level will be introduced to the AQS center in a timely manner.

SECTION 1. SET-UP & TESTING

1.1 ASSEMBLY OVERVIEW

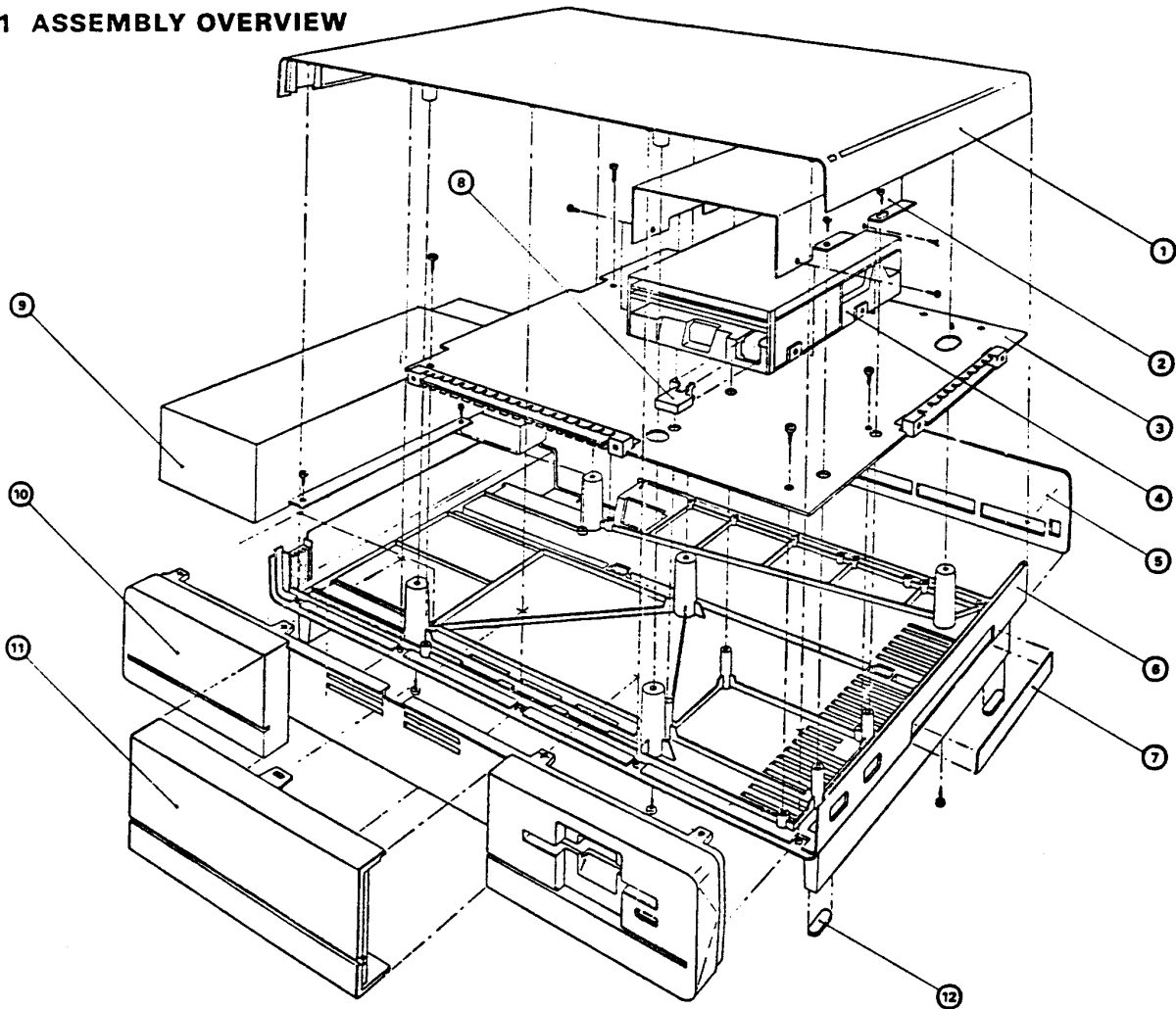

ASSEMBLY OVERVIEW

THE MAJOR ASSEMBLIES IDENTIFIED

NOTE: A complete list of assembly and accessory parts for the AMIGA 1000 computer is given in the parts/price list, titled assembly level parts.

POS.	DESCRIPTION	PART NO.	QTY.
1	HOUSING, TOP	327002-01	1
2	BRKT., DISK DRIVE MTG.	327013-01	1
3	P.C.B	327137-01	1
4	DISK DRIVE	327156-01	1
5	HOUSING, REAR PANEL	327003-01	1
6	HOUSING-BOTTOM	327001-01	1
7	COVER, EXPANSION	327020-01	1
8	BUTTON	327006-01	1
9	POWER SUPPLY	327173-01	1
10	BEZEL	327004-01	1
11	COVER, RAM DISPLAY	327005-01	1
12	FOOT	327054-01	5

1.2 PRELIMINARY NOTES

Required Equipment:

- Kickstart Disk
- Workbench Disk
- Workbench Dealer Demo Disk
- Blank Disk or Disk for Testing
- Monitor
- RAM Expansion Cartridge 1050
- Mouse or Keyboard
- Known Good Drive
- Known Good PCB
- Oscilloscope

OPTIONAL: Service Diagnostic Aide

If a SOFTWARE PROBLEM is suspected, verify that the software package operates CORRECTLY ON A "Known Good" system before beginning test on the "Suspected Bad" system.

1.2.1 When the system is POWERED-DOWN, it should be left OFF for at least 5 seconds before it is powered up again.

IF THIS IS NOT DONE, THE AC POWER SWITCH MAY FAIL.

Whenever possible, RESET the system by depressing the "CNTRL" key and both "A" keys, simultaneously.

1.2.2 It may be necessary to insert a diskette MORE THAN ONCE before it is seated correctly in the drive. Continued difficulty in correctly seating the disk indicates a defective or incompatible disk or a drive mechanical problem.

1.2.3 NEVER remove a disk when the DISK ACCESS LED is ON. Damage to the disk may result. If the system LOCKS-UP, RESET it by depressing the "CNTRL" key and both "A" keys, simultaneously.

1.2.4 If a PCB is replaced, ALL case and shield screws must be re-installed.

IF SCREWS ARE MISSING, EXCESSIVE RF NOISE MAY RESULT.

1.2.5 The GROUND STRAP on the drive assembly must be connected when the disk is being accessed.

IF THE GROUND STRAP IS NOT CONNECTED, READ/WRITE ERRORS MAY OCCUR.

1.2.6 If the system LOCKS-UP when the keyboard is disconnected and connected, it may indicate a defective keyboard.

1.2.7 System functions that are displayed as GHOST functions are NOT OPERATIONAL at this time. An attempt to use those functions may appear to be a malfunction of the system.

1.3 SYSTEM POWER UP

1.3.1 Connect AC power, the keyboard, a mouse (if not available, see below) and the monitor to the AMIGA computer. DO NOT connect any other devices to the computer at this time.

Mouseless Operation of the Amiga

On the AMIGA, anything you can do with the mouse you can also do from the keyboard:

- Pressing, at the same time, an AMIGA key and one of the cursor keys (the keys with arrows on top that are to the right of and slightly below the RETURN key) moves the Pointer in the direction of the arrow.
- Pressing, at the same time, an AMIGA key, the SHIFT key, and one of the cursor keys also moves the Pointer, but faster.
- Pressing, at the same time, the left AMIGA key and the left ALT key (the key just to the left of the left AMIGA key) is like pressing the Selection button, the left button on the mouse.
- Pressing, at the same time, the right AMIGA key and the right ALT key (the key just to the right of the right AMIGA key) is like pressing the Menu button, the right button on the mouse.

1.3.2 Turn the POWER SWITCH, located on the left side of the system toward the front, to the ON position.

1.3.3 The RED Power LED, located at the left front corner of the system, should BLINK on system power-up, then display solid red.

1.3.4 Check that the unit FAN IS RUNNING by placing your hand near the left rear corner of the computer. A slight amount of air flow should be felt.

1.3.5 In approximately 20 seconds, the screen should turn white and, approximately 5 seconds later, a hand should be displayed holding a diskette labeled KICKSTART.

The system is requesting the Boot-Up diskette, called KICKSTART, to be inserted. When the system reaches this point, it is a good indication that the system data and address lines are all operating.

- If the above sequence of steps occur CORRECTLY, continue to SYSTEM DRIVE TEST on page 1-6.
- If the above sequence of steps DO NOT occur, continue to POWER SUPPLY TEST on page 1-4.

1.4 POWER SUPPLY TEST

1.4.1 Remove the TOP COVER and SHIELD from the computer.

- Refer to SECTION 2, COMPUTER DISASSEMBLY, Steps 2.3 and 2.4.

1.4.2 Using an oscilloscope, measure the following signals at the power supply connector, J14:

- | | | | | |
|------------|---------------|-------------|------------|---------------|
| A. Pin 1 | — Purple Lead | — Cnnct J14 | — Should = | -5 VDC |
| B. Pin 2 | — Orange Lead | — Cnnct J14 | — Should = | +12 VDC |
| C. Pin 3,4 | — Black Leads | — Cnnct J14 | — Should = | Sys GND |
| D. Pin 5,6 | — Red Leads | — Cnnct J14 | — Should = | +5 VDC |
| E. Pin 7 | — Gray Lead | — Cnnct J14 | — Should = | 60 Hz / 50 Hz |

- If ALL readings are CORRECT, continue to 1.5 VIDEO OUTPUT CHECK.
- If ANY readings are INCORRECT, continue to Step 1.4.3 below.

1.4.3 Unplug connector J14 from the PCB and measure the molex connector.

- | | | | | |
|------------|---------------|-------------|------------|---------------|
| A. Pin 1 | — Purple Lead | — Cnnct J14 | — Should = | -5 VDC |
| B. Pin 2 | — Orange Lead | — Cnnct J14 | — Should = | +12 VDC |
| C. Pin 3-4 | — Black Leads | — Cnnct J14 | — Should = | Sys GND |
| D. Pin 5-6 | — Red Leads | — Cnnct J14 | — Should = | +5 VDC |
| E. Pin 7 | — Gray Lead | — Cnnct J14 | — Should = | 60 Hz / 50 Hz |

- If ALL readings are CORRECT, continue to Step 1.4.4 below.
- If ANY readings are INCORRECT, REPLACE the power supply.

Refer to SECTION 2, COMPUTER DISASSEMBLY, Steps 2.5, 2.6, 2.7.

1.4.4 Plug connector J14 into the PCB and unplug connector J13. Measure at connector J14.

- | | | | | |
|------------|---------------|-------------|------------|---------------|
| A. Pin 1 | — Purple Lead | — Cnnct J14 | — Should = | -5 VDC |
| B. Pin 2 | — Orange Lead | — Cnnct J14 | — Should = | +12 VDC |
| C. Pin 3-4 | — Black Leads | — Cnnct J14 | — Should = | Sys GND |
| D. Pin 5-6 | — Red Leads | — Cnnct J14 | — Should = | +5 VDC |
| E. Pin 7 | — Gray Lead | — Cnnct J14 | — Should = | 60 Hz / 50 Hz |

- If ALL readings are CORRECT, REPLACE the DRIVE MECHANISM.

Refer to SECTION 2, COMPUTER DISASSEMBLY, Step 2.5.

- If ANY readings are INCORRECT, REPLACE the POWER SUPPLY.

Refer to SECTION 2, COMPUTER DISASSEMBLY, Steps 2.5, 2.6 and 2.7.

1.5 VIDEO OUTPUT CHECK

1.5.1 Measure signals on the PCB at locations:

- A. Resistor R16 —Should = Approx. +5 Volt Composite Sync
- B. Resistor R23 —Should = Approx. +1 Volt Analog Blue
- C. Resistor R24 —Should = Approx. +1 Volt Analog Green
- D. Resistor R25 —Should = Approx. +1 Volt Analog Red

- If ALL readings are CORRECT, check MONITOR and CABLE CONNECTIONS.
- If MONITOR and CONNECTIONS ARE OK, REPLACE the COMPUTER PCB.
Refer to SECTION 2, COMPUTER DISASSEMBLY, Steps 2.5 and 2.6.
- If ANY readings are INCORRECT, REPLACE the COMPUTER PCB.
Refer to SECTION 2, COMPUTER DISASSEMBLY, Steps 2.5 and 2.6.

NOTE: WRITE-PROTECT ALL VOLUME DISKS BEFORE BEGINNING!

- Slide the write-protect tab up toward the edge of the disk to expose the small hole in the disk case.

1.6 SYSTEM DRIVE TEST

1.6.1 Insert the diskette labeled KICKSTART into the internal drive.

At this time, the screen should turn white as the system loads the disk. The drive activity light will flash briefly and the drive access sounds should be heard. After approximately 30 seconds and some screen changes, the system should display a hand holding a diskette labeled WORKBENCH.

- If the hand holding the diskette labeled KICKSTART REAPPEARS, re-seat the diskette and RETRY. If after 3 or 4 retries, the system still does not accept the KICKSTART diskette, try a DIFFERENT COPY of the disk.
- If the disk still WILL NOT LOAD, continue to 1.7 DRIVE ASSEMBLY CHECK.

1.6.2 Remove the KICKSTART disk.

1.6.3 Insert the diskette labeled WORKBENCH into the internal drive.

At this time, the screen will turn white for approximately 2 seconds and then display the boot-up message while continuing to load from the disk.

- If the hand holding the diskette labeled WORKBENCH REAPPEARS, re-seat the diskette and RETRY. If after 3 or 4 retries, the system still does not accept the WORKBENCH diskette, try a DIFFERENT copy of the disk.
- If the disk STILL WILL NOT LOAD, continue to 1.7 DRIVE ASSEMBLY CHECK.

When loading is complete, the screen will be blue with the WORKBENCH DISK ICON in the upper right hand corner. The TITLE BAR message will be:

Amiga Workbench Version 1.0 167840 free memory

1.6.4 Select the WORKBENCH ICON with the mouse.

With the mouse, move the pointer on to the ICON and click the left button once. The ICON will turn black to indicate it has been selected.

1.6.5 Select DUPLICATE from the menu:

Press and hold the right mouse button while sliding the pointer to the upper left corner of the title bar. When the pointer is over the word Workbench, the word will highlight and the menu selection will be displayed.

Continue to depress the right mouse button and slide the pointer down to the word DUPLICATE and, when DUPLICATE is highlighted, release the right mouse button.

The DISKCOPY WINDOW will be displayed and will continue to prompt you through the entire DISKCOPY procedure.

1.6.6 Select CONTINUE with the left mouse button.

- WRITE-PROTECT YOUR VOLUME COPY OF WORKBENCH by sliding the tab to the UP position (toward the edge of the disk, open hole can be seen).

1.6.7 Follow the DISKCOPY instructions as they are displayed on the screen and select CONTINUE with the left mouse button until the copy is complete.

- During the DISKCOPY the drive is writing, reading and verifying data. If the copy is completed without a problem continue to 1.6.8.
- If a problem is encountered, try a DIFFERENT DESTINATION DISK or a DIFFERENT SOURCE DISK.
- If the problem continues, refer to 1.7 DRIVE ASSEMBLY CHECK.

1.6.8 Select the VOLUME WORKBENCH DISK with the mouse.

With the pointer on the WORKBENCH DISK ICON, double-click the left mouse button. The WORKBENCH WINDOW will be displayed.

1.6.9 Select PREFERENCES.

With the pointer on the PREFERENCES ICON, double-click the left mouse button. The screen will clear and then display the WINDOW to select preferences.

1.6.10 Set the CLOCK.

Position the pointer on one of the numbers depicting the time. Click the left mouse button once, move the pointer to the up/down arrows and then advance the selected number with successive clicks of the left mouse button.

Continue until the correct time is set on the 24 hour clock.

1.6.11 SAVE the preferences you have set, to TEST the WRITE-PROTECT SENSOR.

Move the pointer to the gadget marked SAVE and click the left mouse button.

- If the SYSTEM REQUEST WINDOW appears and indicates that the disk is WRITE-PROTECTED, continue to 1.6.12.
- If the preferences ARE saved to the disk with the write-protect tab set correctly on the disk, the write-protect sensor is DEFECTIVE. EXCHANGE THE DRIVE ASSEMBLY.

Refer to SECTION 2, COMPUTER DISASSEMBLY.

1.6.12 CANCEL the preferences save.

Move the pointer to the CANCEL gadget and click the left mouse button.

- IF THE DRIVE HAS SUCCESSFULLY PASSED ALL OF THESE EXERCISES, IT SHOULD BE ASSUMED THAT IT IS A GOOD DRIVE. Continue to 1.8 SYSTEM PCB TEST to verify a possible hardware failure.

1.7 DRIVE ASSEMBLY CHECK

1.7.1 Follow the DISASSEMBLY sequence in SECTION 2 to obtain access to the drive.

1.7.2 To check an internal DRIVE ASSEMBLY, disconnect the ground, power and ribbon cables from the back of the drive. Place a "known good" drive assembly on top of the installed drive and connect the cables to it.

1.7.3 Power-up the system and begin testing from the start.

- If the system now PASSES all tests, EXCHANGE the DRIVE ASSEMBLY.
- If the system still FAILS, a PCB exchange will be necessary.

Refer to SECTION 2, COMPUTER DISASSEMBLY.

1.8 SYSTEM PCB TEST

1.8.1 Select the CLOCK ICON.

Position the pointer on the clock and double-click the left mouse button. The clock window will be displayed.

Check for CORRECT TIME and that the display is NOT DISTORTED.

- If INCORRECT, refer to 1.9 PCB CHECK.

1.8.2 Drag the CLOCK WINDOW to the lower right corner of the screen.

Position the pointer on the DRAG BAR, depress the left mouse button, move the clock window and release the mouse button.

Now the WORKBENCH ICONS are accessible and the CLOCK WINDOW remains visible.

1.8.3 Select the DEMOS DRAWER.

Position the mouse on the DEMOS DRAWER and double-click the left mouse button.

The DEMOS WINDOW will appear.

1.8.4 Select DOTS, then BOXES and then LINES.

Position the pointer on each ICON and double-click the left mouse button to load each DEMO.

The DEMO WINDOWS will appear overlapping each other. Verify that each DEMO is loaded and running.

NOTE: That as each demo is selected, the amount of FREE MEMORY is REDUCED.

- If ALL DEMOS and the CLOCK are running properly, continue to 1.8.5.
- If the CLOCK is DISTORTED or the DEMOS will NOT RUN, refer to 1.9 PCB CHECK.

1.8.5 CLOSE the DEMOS and the DEMO WINDOW.

Position the pointer on the CLOSE GADGET (in the upper left corner) of each open DEMO and click the left mouse button once.

NOTE: As each window is closed, additional FREE MEMORY blocks should be added to the TITLE BAR.

Verify that the CLOCK is still running correctly.

- If NO PROBLEM is encountered, CONTINUE to 1.8.6.
- If the CLOCK is DISTORTED or a problem is encountered, refer to 1.9 PCB CHECK.

1.8.6 Insert the dealer WORKBENCH DEMOS disk.

The WORKBENCH DEMOS disk ICON will appear in the upper right quadrant of the screen.

1.8.7 Select the ICON for WORKBENCH DEMOS.

Position the pointer on the ICON and double-click the left mouse button.

The WORKBENCH DEMO WINDOW will appear in the lower right corner, blocking view of the clock, temporarily.

1.8.8 Select the GRAPHICS DRAWER.

When the WORKBENCH DEMOS WINDOW appears, position the pointer on the GRAPHICS drawer and double-click the left mouse button.

CAUTION:

All other demos on the WORKBENCH DEMO DISK will NOT run without memory expansion. Sufficient memory is available to run the GRAPHICS demos ONE AT A TIME.

1.8.9 CLOSE the WORKBENCH DEMOS WINDOW.

Position the pointer on the CLOSE GADGET and click the left mouse button once.

The CLOCK will be visible again.

1.8.10 Select the FIELDS graphic demo.

Position the pointer on the FIELDS balloon and double-click the left mouse button.

The screen will become white and a "bouncing" line will be seen. Within a few seconds the line will split to several different color planes constantly moving on the screen changing their size, shape and color.

Verify that:

Images move smoothly.
Edges of colored planes are sharp and jagged.
Colors do not bleed outside of shape.
Background is clear-free of color speckles.

- If INCORRECT, refer to 1.9 PCB CHECK.
- If CORRECT, continue to 1.8.11.

1.8.11 Access the WORKBENCH screen.

With the mouse, move the pointer to the upper edge of the screen until it can go no farther.

Depress and hold the left mouse button and simultaneously move the mouse down to view the WORKBENCH screen.

Verify that:

Free memory in the title bar is periodically updated.
Clock is running properly.

- If INCORRECT, refer to 1.9 PCB CHECK.
- If CORRECT, continue to 1.10 RAM EXPANSION TEST.

NOTE: For COMPLETE SYSTEM TEST the RAM EXPANSION TEST MUST BE RUN. It is the best exercise of the CUSTOM CHIPS available at this time.

1.9 PCB CHECK

NOTE: Initially, it may be necessary to replace the PCB entirely to check if a PCB EXCHANGE is necessary. Follow the disassembly/assembly instructions in Sections 2 and 3. Once the DIAGNOSTIC AIDE is available in the field, you may confirm proper operation of the system by following these steps:

1.9.1 Place a "known good" PCB on the bench beside the unit under test.

- Refer to SECTION 2, COMPUTER DISASSEMBLY, to open case and remove shield.

1.9.2 The DIAGNOSTIC AIDE is a straight-through test device that enables you to run the system from the "known good" board. Position the DIAGNOSTIC AIDE over the holes in the casework at the front of the unit.

1.9.3 Remove the cables from the unit PCB and connect them to the DIAGNOSTIC AIDE as indicated.

1.9.4 Attach the DIAGNOSTIC AIDE cables to the "known good" board and it will now run the system.

1.9.5 Return to SYSTEM TEST and begin test from the start.

- If the system now PASSES all tests, EXCHANGE THE PCB ASSEMBLY.
- If the system still FAILS, verify that your "known good" PCB is in fact GOOD.

1.10 RAM EXPANSION TEST

1.10.1 Turn system OFF.

1.10.2 Remove RAM EXPANSION COVER from front of computer.

1.10.3 Insert RAM EXPANSION CARTRIDGE A1050.

Install the cartridge straight onto the card edge connector.

Be certain it is secure.

1.10.4 Replace RAM EXPANSION COVER.

1.10.5 Power ON.

1.10.6 Insert the diskette labeled KICKSTART into the internal drive.

At this time, the screen should turn white as the system loads the disk. The drive activity light will flash briefly and the drive access sounds should be heard. After approximately 30 seconds and some screen changes, the system should display a hand holding a diskette labeled WORKBENCH.

- If the hand holding the diskette labeled KICKSTART REAPPEARS, re-seat the diskette and RETRY. If after 3 or 4 retries, the system still does not accept the KICKSTART diskette, try a DIFFERENT COPY of the disk.
- If the disk still WILL NOT LOAD, refer to 1.7 DRIVE ASSEMBLY CHECK

OR

- If the drive was previously tested as OK, EXCHANGE the RAM EXPANSION CARTRIDGE and RETRY.

1.10.7 Remove the KICKSTART disk.

1.10.8 Insert the diskette labeled WORKBENCH into the internal drive.

At this time, the screen will turn white for approximately 2 seconds and then display the boot-up message while continuing to load from the disk.

- If the hand holding the diskette labeled WORKBENCH REAPPEARS, re-seat the diskette and RETRY. If after 3 or 4 retries, the system still does not accept the WORKBENCH diskette, try a DIFFERENT copy of the disk.
- If the disk STILL WILL NOT LOAD, refer to 1.7 DRIVE ASSEMBLY CHECK.

OR

- If the drive was previously tested as OK, EXCHANGE THE RAM EXPANSION CARTRIDGE and RETRY.

When loading is complete, the screen will be blue with the WORKBENCH DISK ICON in the upper right hand corner. The TITLE BAR message will be:

Amiga Workbench Version 1.0 429928 free memory.

1.10.9 Insert the DEALER WORKBENCH DEMO DISK Version 1.0.

The WORKBENCH DEMOS ICON will appear and the TITLE BAR will be updated to:

Amiga Workbench Version 1.0 428704 free memory.

1.10.10 Select the WORKBENCH DEMOS ICON with the mouse.

With the mouse, move the pointer on to the ICON and double-click the left button.

1.10.11 Select the ANIMATIONS DRAWER from the WORKBENCH DEMOS window.

With the pointer on the drawer, double-click the left mouse button.

1.10.12 Select ROBO-CITY from the ANIMATIONS window.

With the pointer on the FIGURE for Robo-City double-click the left mouse button.

Verify that:

Images move correctly
Colors do not bleed

- If INCORRECT, refer to 1.9 PCB CHECK. Problem may be the CUSTOM CHIPS on the main board.

OR

Exchange the 1050 RAM EXPANSION CARTRIDGE and RETRY.

- If CORRECT, continue to 1.10.13.

1.10.13 Access the WORKBENCH screen.

With the mouse, move the pointer to the upper edge of the screen until it can go no farther.

Depress and hold the left mouse button and, at the same time, move the mouse back to view the WORKBENCH screen.

1.10.14 Close ROBO-CITY and the ANIMATIONS window.

Position the pointer on the CLOSE GADGET for each window and click the left mouse button once.

1.10.15 Open the PICTURES drawer.

Position the pointer on the PICTURES drawer and double-click the left mouse button.

NOTE: With the RAM EXPANSION CARTRIDGE added, ALL PICTURES are accessible. However the MANDRIL is the best test that the system is working properly.

1.10.16 Load MANDRIL from the PICTURES window.

Position the pointer on the MANDRIL balloon and double-click the left mouse button.

Verify that:

MANDRIL display is complete
Colors do not bleed

The CLOSE GADGET for MANDRIL is not operational in Version 1.0. Therefore, it is necessary to RESET the system with the AMIGA/CTRL keys if additional testing is desired.

- If INCORRECT, refer to 1.9 PCB CHECK. Problem may be the CUSTOM CHIPS on the main board.

OR

EXCHANGE the 1050 RAM EXPANSION CARTRIDGE and RETRY.

- If CORRECT, the main PCB and RAM EXPANSION CARTRIDGE should be considered GOOD.

1.11 KEYBOARD TEST

NOTE: At present, the best procedure to check a keyboard is by using NOTEPAD. If additional help is needed to load NOTEPAD refer to 1.6 SYSTEM DISK TEST and 1.7 SYSTEM PCB TEST.

1.11.1 Insert KICKSTART disk when prompt appears.

1.11.2 Insert WORKBENCH disk when prompt appears.

1.11.3 Select WORKBENCH disk ICON.

1.11.4 Select UTILITIES DRAWER from WORKBENCH WINDOW.

1.11.5 Select NOTEPAD from UTILITIES WINDOW. Wait for the NOTEPAD to turn white before beginning keyboard test.

1.11.6 Hit every key to verify proper operation. Function keys appear on the screen as ~.

1.11.7 Check the LED operation on the CAPS LOCK key.

- If any key operation is INCORRECT, EXCHANGE KEYBOARD and RETRY.
- If all key operations are CORRECT, KEYBOARD should be considered GOOD.

SECTION 2. COMPUTER DISASSEMBLY

PLEASE NOTE: The disassembly of the AMIGA 1000 should only be attempted by a qualified technician using proper static protection procedures and equipment.

2.1 REAR CONNECTORS

2.1.1 Set power switch to OFF position and remove power cord.

2.1.2 Remove all peripheral cables and keyboard connector from rear of unit. See Fig. 2-1.

2.1.3 Remove mouse from connector, if present. See Fig. 2-2.

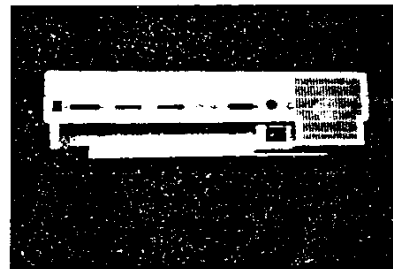

Fig. 2-1. Rear Connectors

2.2 KEYBOARD

2.2.1 If keyboard replacement is necessary, remove keyboard cable from keyboard assembly, **DO NOT REMOVE KEYBOARD FROM CASE ASSEMBLY**. Warranty exchange is for the entire keyboard assembly, as shown in Fig. 2-3.

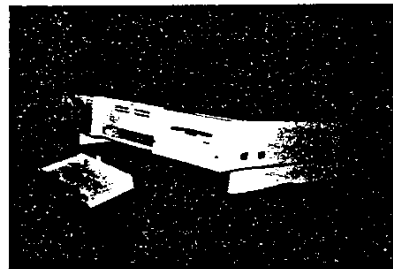

Fig. 2-2. Front/Side View

2.3 OPENING THE CASE

2.3.1 With the computer facing you and the drive on your right, remove the RAM DISPLAY COVER by applying light pressure on the top and bottom of the center panel and gently pulling toward you. See Fig. 2-2.

2.3.2 If a RAM EXPANSION card has been installed, remove it by gently pulling the expansion card toward you.

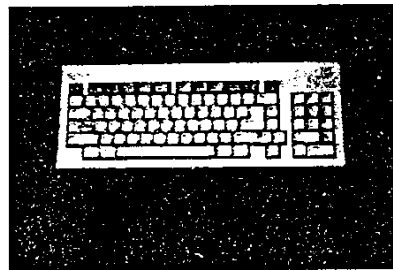

Fig. 2-3. Keyboard

2.3.3 Turn the computer up-side down and remove the 5 self-tapping screws from the hollows of the bottom housing. See Fig. 2-4.

NOTE: It is a good idea to keep all screws in small containers in the order that they are removed. A board swap of the AMIGA will require the removal of 34 screws of several types and lengths.

2.3.4 Remove the 2 flush-mount screws located by the front bezel. See Fig. 2-4.

2.3.5 Holding the case together, turn the AMIGA right-side up with the front facing you and the drive to your right.

2.3.6 The TOP HOUSING snaps into the bottom housing, so remove by applying a slight outward pressure on the bottom housing, or inward pressure on the top housing, at the rear corners of the computer. See Fig. 2-5. Set the top housing aside.

NOTE: In the following step, there are 2 sets of LED wires connected to the front BEZEL. Care should be taken not to pull these tight when removing this panel.

2.3.7 With the top cover already off, the front BEZEL can be removed by gently working it forward, away from the rest of the computer. Lay the BEZEL in front of the computer, temporarily, as shown in Fig. 2-6.

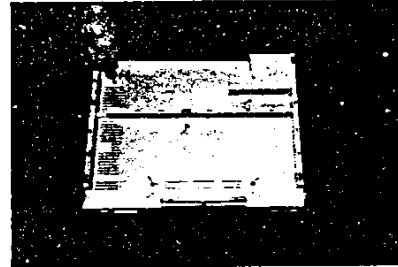

Fig. 2-4. Bottom View

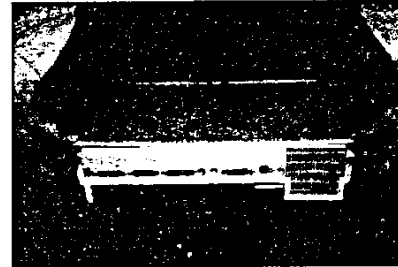

Fig. 2-5. Top Housing Removal

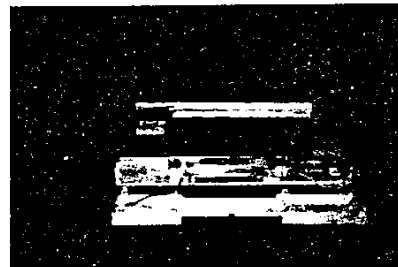

Fig. 2-6. Front Bezel Removal

2.4 REMOVING THE TOP RFI SHIELD

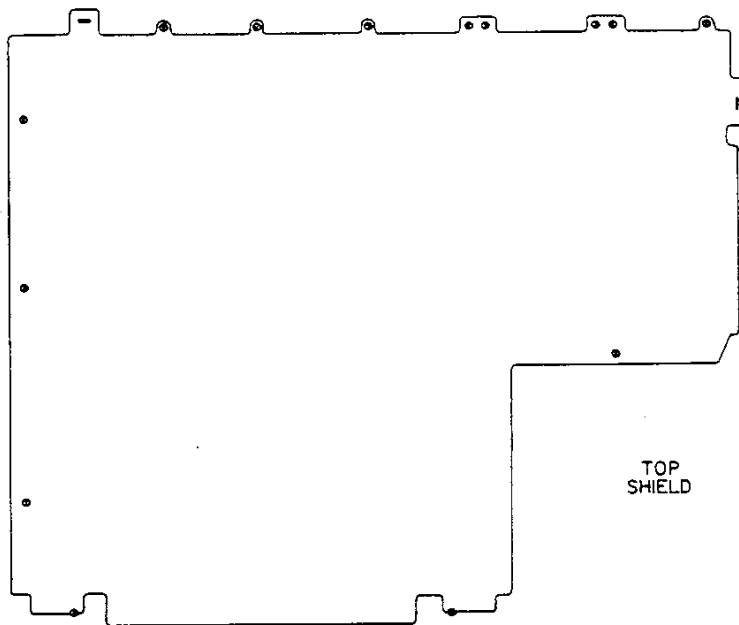

Fig. 2-7. Shield Screw/Tab Locations

2.4.1 As shown in Fig. 2-7, remove the following screws:

QTY	LOCATION
8	EACH SIDE OF REAR CONNECTORS
3	ALONG TOP OF POWER SUPPLY ASSY
1	FLUSH MOUNTED TOP REAR OF DRIVE
2	AT FRONT OF PCB

2.4.2 Untwist the 2 shield tabs at the right side towards the rear and the rear left corner.

2.4.3 Gently work shield loose from the PCB assembly.

2.4.4 At this time, the LED harnesses connected to the front BEZEL can be unplugged. The drive LED wire disconnects at an in-line connector and the power LED disconnects at the PCB, J15 as shown in Fig. 2-8. Set the front BEZEL aside.



Fig. 2-8. LED Harness Removal

NOTE: The Printed Circuit Board (PCB) in the AMIGA is mapped with letters along the front edge of the PCB and numbers up the left side. Map locations for items described in the text are listed as the intersections of these points. An indication of C2, for instance, indicates the board area where a line, running vertically from the 'C' marked on the PCB edge and horizontally across from the '2' printed on the left of the PCB, intersects. The map points in this text are estimates of the PCB area in which a connector or screw may be found.

2.5 DRIVE REMOVAL

2.5.1 Remove the 4 brass stand-offs located at the connectors J10 and J11 at board locations T1, T2, T3, T4. See Fig. 2-10.

2.5.2 Remove the 4 screws from the sides of the drive bracket at locations T2, T4, L2, L4.

2.5.3 Remove the following cables:

CABLE	LOCATION
LOGIC RIBBON	R8
POWER	H7

2.5.4 Lift the drive away from the PCB and disconnect the ground wire at T4. See Fig. 2-11.

2.5.5 Cut the plastic tie-wrap that holds the LED cable at location T1.

2.5.6 IF A DRIVE EXCHANGE IS NECESSARY, REMOVE AND RETAIN THE RIBBON AND POWER CABLES FROM THE DRIVE ASSEMBLY.

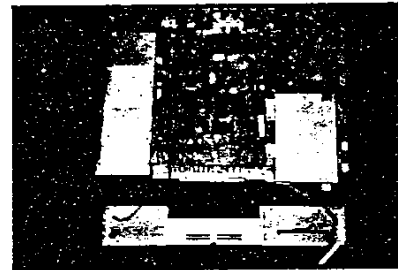

Fig. 2-9. Internal View

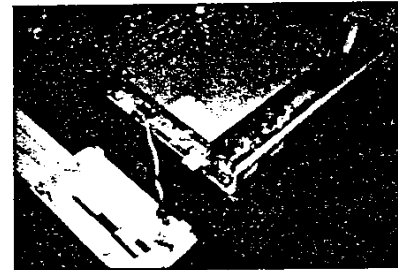

Fig. 2-10. Stand-Off Locations

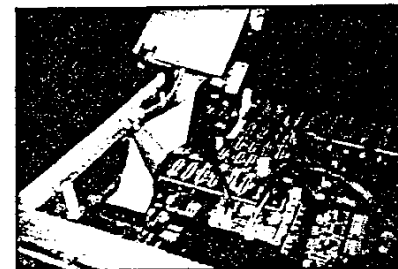

Fig. 2-11. Drive Cable Locations

2.6 PCB REMOVAL

CAUTION: Do NOT remove the 4 screws that secure the card edge connector shields at locations.

2.6.1 Disconnect the power supply cable at location G7.

2.6.2 Remove the 4 PCB screws at locations A1, A6, T1, T4. Note that the power supply screws are larger than the other two. See Fig. 2-12.

2.6.3 Gently lift the PCB from the bottom case. To clear the mouse connectors, you will have to lift the power supply side of the board up first and lightly push the right-side bottom housing away from the PCB. The rear panel housing will come off with the PCB and may require slight pressure during PCB removal to keep it from binding in its tracks, as shown in Fig. 2-13.

2.6.4 To remove the LOWER RFI SHIELD from the PCB, untwist the 8 tabs at locations A1, A4, A9, A10, T9, T3, N1, J1.

2.7 POWER SUPPLY REMOVAL

2.7.1 To remove the power supply, move the assembly toward the left side of the case to disengage the bottom case feet. Lift the power supply from the bottom case. See Fig. 2-15.

2.7.2 Power supply WARRANTY EXCHANGE is for the entire assembly as it is shown when removed from the bottom case.

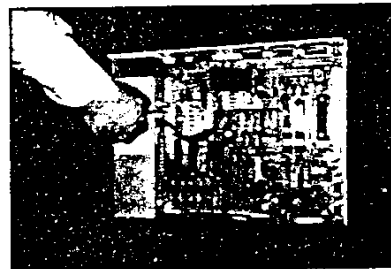

Fig. 2-12. PCB Screw Removal

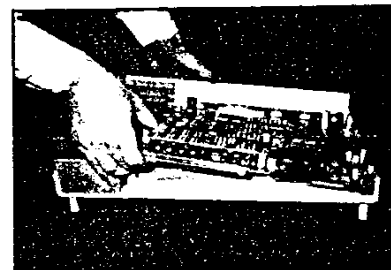

Fig. 2-13. PCB Removal

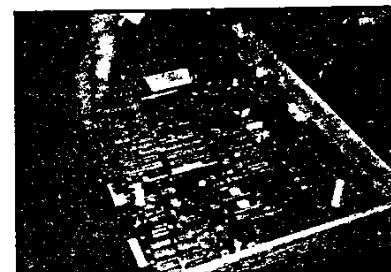

Fig. 2-14. Rear Housing Clearance

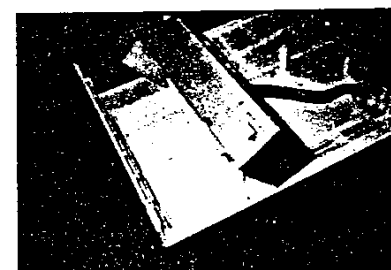

Fig. 2-15. Power Supply Removal

SECTION 3. AMIGA ASSEMBLY

3.1 POWER SUPPLY INSTALLATION

3.1.1 To install the power supply into the bottom case, insert the assembly on an angle to engage the slots in the bottom case. See Fig. 3-1.

3.1.2 Check that the power supply assembly is installed properly before continuing to the next step.

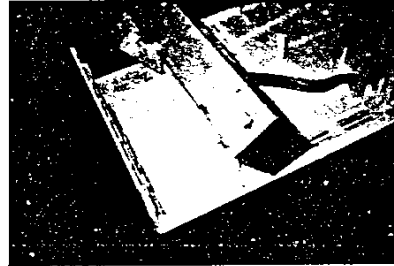

Fig. 3-1. Power Supply Insertion

3.2 PCB INSTALLATION

3.2.1 Install the LOWER RFI SHIELD on the bottom of the PCB and twist the 8 tabs at locations A1, A4, A9, A10, T9, T3, N1, J1.

3.2.2 Gently insert the PCB into the bottom case. To clear the mouse connector cut-outs, you will have to insert the board on an angle while gently holding the right-side bottom housing out. See Fig. 3-2. The rear panel housing must be inserted along with the PCB. While holding it in place over the rear connectors, slide it into its tracks, as shown in Fig. 3-3.

3.2.3 Install the 4 PCB screws at locations A1, A6, T1, T4. Note that the power supply screws are larger than the other two.

3.2.4 Connect the power supply cable at location G7.

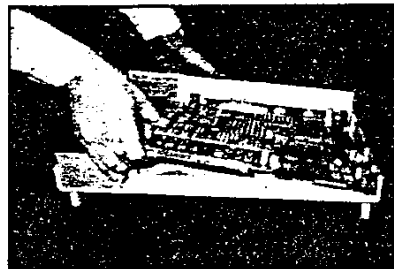

Fig. 3-2. Clearing the Right Side Connectors

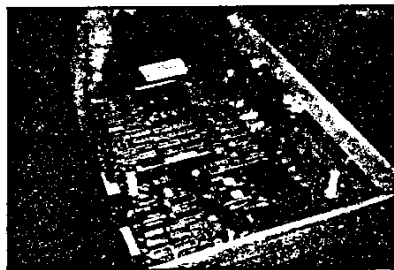

Fig. 3-3. Rear Housing Insertion

3.3 DRIVE INSTALLATION

3.3.1 Position the drive over the PCB and re-connect the ground wire at T4. See Fig. 3-4.

3.3.2 Install the 4 screws in the sides of the drive bracket at locations T2, T4, L2, L4. See Fig. 3-5.

3.3.3 Install the 4 brass stand-offs located at the connectors J10 and J11 at board locations T1, T2, T3, T4. See Fig. 3-6.

3.3.4 Connect the following cables:

CABLE	LOCATION
LOGIC RIBBON	R8
POWER	H7

Note that the ribbon cable is mounted with the ribbon coming out of the connector towards the front of the computer.

3.3.5 Replace the plastic tie-wrap that holds the LED cable at location T1. The cable must be secured to be certain that it will not interfere with drive operation.

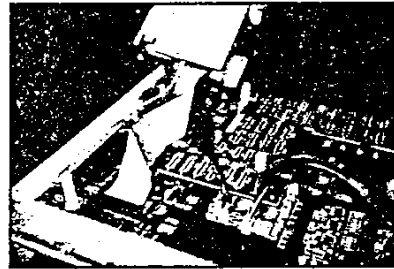

Fig. 3-4. Drive Cable Locations

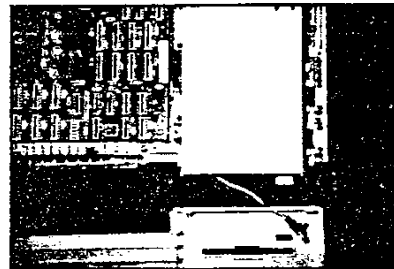

Fig. 3-5. Drive Screw Locations

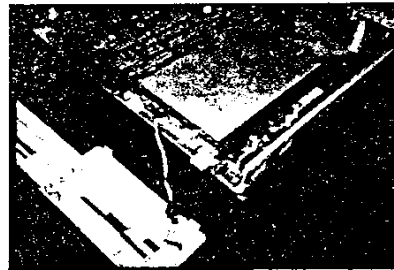

Fig. 3-6. Stand-off Locations

3.4 INSTALLING THE TOP RFI SHIELD

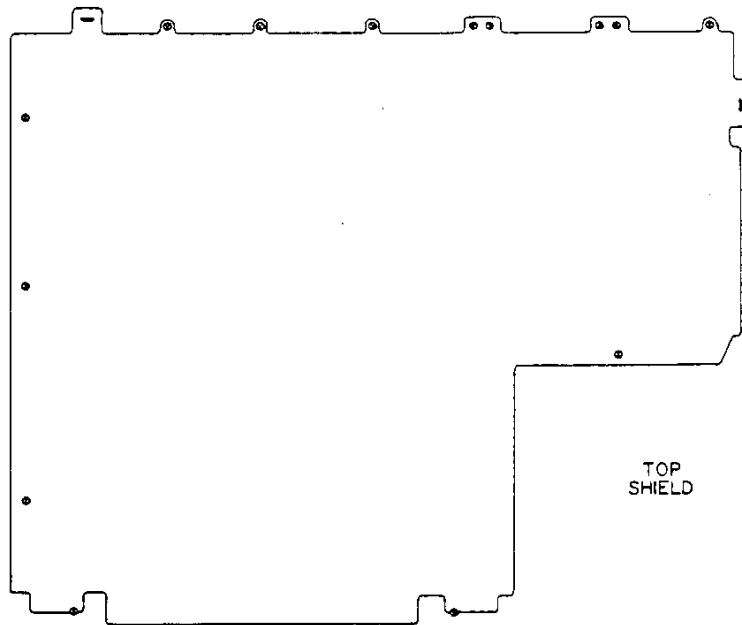

Fig. 3-7. Shield Screw/Tab Locations

3.4.1 Place the front bezel on the work surface, in front of the unit, and install the LED harnesses. The drive LED harness is an in-line connector and the power LED connects at the PCB, J15. See Fig. 3-8.

3.4.2 Gently position shield into place over the PCB assembly.

3.4.3 Twist the 2 shield tabs at the right side towards the rear and the rear left corner. The positions are indicated in Fig. 3-7 with a short line.

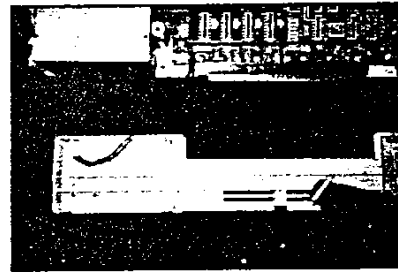

Fig. 3-8. LED Harness Installation

3.4.4 As shown in Fig. 3-7, install the following screws:

QTY	LOCATION
8	EACH SIDE OF REAR CONNECTORS
3	ALONG TOP OF POWER SUPPLY ASSY
1	FLUSH MOUNTED TOP REAR OF DRIVE
2	AT FRONT OF PCB

3.5 BEZEL AND CASE INSTALLATION

3.5.1 Place the front bezel in its place within the bottom case, being careful to line up the round holes in the tabs with the matching extensions. See Fig. 3-9.

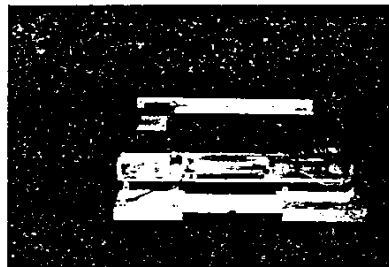

Fig. 3-9. Front Bezel with Tab Positions

3.5.2 The TOP HOUSING snaps into the bottom housing. Inward pressure on the top housing, at the rear corners of the computer, may be necessary to replace the cover without using excessive force. See Fig. 3-10.

3.5.3 Holding the case together, turn the AMIGA upside down.

3.5.4 Install the 2 flush-mount screws located by the front bezel. Be certain NOT to OVERTIGHTEN these screws.

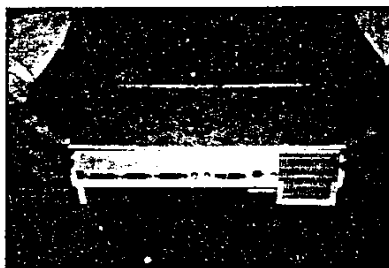

Fig. 3-10. Installing the Top Housing

3.5.5 Install the 5 self-tapping screws into the hollows of the bottom housing. See Fig. 3-11.

3.5.6 Return the computer to its upright position with the drive facing front and to the right. Install the RAM EXPANSION card, if necessary.

3.5.7 Replace the RAM DISPLAY COVER by applying light pressure at the center panel and gently snapping it into place.

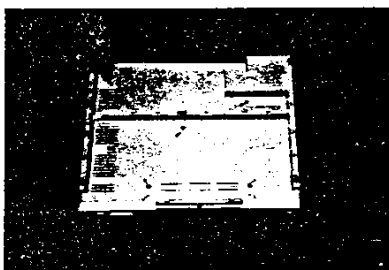

Fig. 3-11. Installing the Case Screws

BASIC OPERATING THEORY
COMMODORE-AMIGA 1000 SYSTEM

2.0 Version
Slide Presentation

SLIDE 1 -- AMIGA BLOCK

The Amiga 1000 System actually utilizes two 16 Bit Bi-directional Data Buses and four Address Buses. The Data Bus connects the System RAM to all 3 Custom ICs and 68000 MPU through Bi-Directional Tri-State Buffers.

DATA BUSES

1. One of the Data Buses, (On Left), is called the Micro Processor, (uP), or 68K Data Bus, (PD0-PD15), and is used to connect the 68000 MPU to the Expansion Bus, O/S RAM/ROM and the 8520 CIA Chips.
2. The other Data Bus is called the Display/uP Data Bus, (D0-D15), and is used to connect the System RAM directly to all three Custom Chips and also to the 68000 MPU through a Bi-Directional Tri-State Buffer when no DMA is occurring.

ADDRESS BUSES

1. One Address Bus, (A1-A23 - Not Shown), is a 23 Bit Bus and is generated either by the 68000 MPU or an External Bus Master.
2. One Address Bus is 8 Bits Multiplexed, (RA0-RA7), (Low Bits), and is generated by either Agnus or the 68000 MPU. If this bus is generated by Agnus the multiplexing is done, (Hi to Lo Bit), if it is generated by the 68000 MPU it must *BE MULTIPLEXED BEFORE RAM ACCESS.*

~~to RAM:~~

(Lo - Hi Bits Shown on Amiga Block)

3. One Address Bus is 18 Bits, (Multiplexed to 9 - DRA0-DRA8), generated by Agnus and is used to address the Dynamic RAMs during DMA or Refresh. (Shown on DMA Read and Agnus Block)
4. One Address Bus is 8 Bits, (RGAL-RGA8), generated by either Agnus or the 68000 and is used for Inner-Chip Communication. During a DMA Cycle, this Bus is Bi-Directional only on Agnus thus allowing Agnus ~~to act as a Co-Processor~~ *TO OPERATE* When no DMA is occurring the RGA Bus is driven by the Lo Address Bits of the 68000 MPU. This allows the 68000 MPU to Read or Write to the Custom Chips as though they were RAM. (Shown on Agnus Block)

This type of design allows the 68000 MPU to run without interference from DMA Cycles used for Display, Blitter etc.

When Agnus decides a DMA Cycle is required, it turns on the Data Bus Request Line, DBR, on a falling edge of the Color Clock, CCK), also known as Cl. The Bus Control Logic, (which contains the 'PALEN' PAL), enables the DMA Address Enable Signal, (DAE), preventing the DTACK Signal which interrupts the 68000 MPU and turns off both Tri-State Buffers.

In this DMA Mode, AGNUS addresses RAM using its RAM Address Bus, DRA, while simultaneously creating a Data Destination Address on the Register Address Bus, RGA. This selects a Register on any of the Custom ICs, including itself, as the RAM Data Destination. All Agnus Cycles are 16 bit Transfers.

BASIC OPERATING THEORY

COMMODORE-AMIGA 1000 SYSTEM

SLIDE 2 -- DMA READ

To understand the Hardware of the Amiga 1000 System is primarily a matter of understanding the 25 DMA, (Direct Memory Access), Channels and their related functions.

Each Channel has an 18 Bit Ram Address Pointer which is placed on the RAM Address Bus and is used to select the location of the DMA Data Transfer from anywhere in the 256k/512K of RAM.

An 8 Bit Destination Address is simultaneously placed on the Register Address Bus sending Data to one of the Custom IC Addresses.

Almost all DMA Channels have RAM for Source and Custom IC Registers as Destination.

SLIDE 4 -- AGNUS BLOCK

The 8361 AGNUS is the Address Generator Chip. Its main function, in chip area, is the RAM Address Generator and Register Address Encoder which provides all DMA Addresses.

The 8361 AGNUS is made up of approximately 21,000 Transistors and contains all DMA Channel Controllers. The Blitter and the Copper are also contained here.

The Register Address Encoder is a basic PLA type of structure that produces a Prewired Address on the Register Address, RGA, Bus whenever a DMA Channel is active.

SLIDE 5 -- ADDRESS GENERATOR

The RAM Address Generator is much more complex. It contains an 18 Bit Pointer Register, for each of the 25 DMA Channels, Pointer Restart Registers and Jump Registers for 6 of the DMA Channels. The full 18 Bit Address carries out the Pointer Increments and adds for jumps.

The Priority Control Logic monitors the Pipelined DMA Requests from each Controller then stages the DMA Cycles based on their Programmed Priority and Sync Counter Time Slot. It then tells the 68000 MPU to get off the bus using the Data Bus Request, DBR, allowing AGNUS control.

SLIDE 6 -- COPPER DMA

The Copper uses 1 DMA Channel. The Copper is the Co-Processor that uses the DMA Channels to fetch its instructions from Memory and write to from it's program in Memory to the Registers in itself or to the other two Custom Chips. The DMA Pointer is the Instruction Counter and must be preloaded with the starting address of the Copper's Instructions.

The Copper can also perform Move, Wait, (Halt), and Skip Instructions.

MOVE - Move Data to a Register

WAIT - Wait Until the Electron Beam Passes a given position

SKIP - Skip Past the next Instruction if the Electron Beam is past a Given Location

BASIC OPERATING THEORY
COMMODORE-AMIGA 1000 SYSTEM

When the Copper is Halted it is off the Data Bus and doesn't use any Bus Cycles until the Wait is over. A Programmed Wait Value is compared to the Beam Counter, which keeps track of the TV beam position. When these 2 values are equal, the Copper resumes fetching instructions.

The Copper can cause Interrupts, reload the Color Registers, start the Blitter or service the Audio. The Copper can modify almost any Register in the Custom
SLIDE 7 -- BLITTER DMA

The Blitter uses 4 DMA Channels, 3 Sources and 1 Destination. Once the Blitter has been started these 4 DMA Channels are synchronized and pipelined to automatically handle the Data Transfers without further 68000 MPU Intervention. The Images are manipulated in memory independent of the display. (Bitplane DMA)

With the three sources A, B, and C along with their inverses, they combine in eight ways for a possible 256 Combinations.

SLIDE 8 -- DENISE BLOCK

The 8362 DENISE is the Display Encoder Chip. The Internal Circuitry of DENISE is comprised of approximately 19,000 Transistors.

The main function is to Buffer Display Data, Select the object to be displayed at any instant and encode the object into Red, Blue and Green Color Codes.

The Bitplane Data is continuously loaded and serialized during the Display Time. The Sprite Data is loaded during Blank Time and serialized individually whenever the Sprite Position Compare Logic detects equality between the Sync Counter and any Sprite Position Register.

The 6 lines of Bit Plane Serial Data and the 8 pairs of Sprite Serial Data feed into the Priority Control Logic which selects only one of the Sprites or one of the Separate Bitmap Images to produce the 5 Bit Color Select Code at the output. This 5 Bit Code selects one of the 32 Color Registers producing the 12 Bit RGB, (Red, Green, Blue), Video Output.

The 6 lines of Bit Plane Serial Data and the 8 pairs of Sprite Serial Data also feed into the Collision Detect Logic which detects Real Time Occurance between them and sets the appropriate bits in the Collision Storage Register. The 68000 MPU Reads and Clears this register.

The 2 Mouse/Joystick Connectors are controlled by 4 Mouse Counters. The Mouse Counters count the Horizontal and Vertical Motion of the Controllers. These counters are read by the 68000 MPU.

SLIDE 9 -- BITPLANE DMA

The Bitplane uses 6 DMA Channels. During display the Bitplane Controller continuously transfers Display Data from memory to Display Buffer Registers. The 6 DMA Channels handle the data from 6 Independent Bitplanes. The Display Buffers convert this Bitplane Data into Pixel Data for the display.

Each Bitplane can be a full image, or a window into an image that is up to 4 times the screen size. They can be grouped into 2 separate images, each with its own Color Registers.

BASIC OPERATING THEORY

COMMODORE-AMIGA 1000 SYSTEM

SLIDE 10 -- SPRITE DMA

There are 8 Sprite Controllers. Each is independent and uses 1 DMA Channel, (3 Total), and has its own dedicated time slot for DMA Data Transfer. Sprites are Line Buffered Objects that can move very fast because positioning is controlled by Hardware Registers and Comparators.

Each Sprite has two 16 Bit Data Registers which define a Sprite 16 Pixels wide with 4 Colors. Each Sprite also has a Horizontal Position Register, Vertical Position Register, Vertical Start Position Register and Vertical Stop Position Register which allows Variable Vertical Size Sprites.

The Sprite DMA Controller fetches Image Data and Position Data automatically from anywhere in the 512K of memory.

Sprites can be run automatically in DMA Mode or loaded and controlled by the 68000 MPU. Each Sprite can be re-used Vertically as often as desired but Horizontal re-use is possible only under control of the 68000 MPU.

SLIDE 11 -- PAULA BLOCK

The 8364 PAULA is the Ports, Audio and Uart Chip. Its main function, in chip area, is the 4 Audio Channels. It also contains the I/O Ports, (Disk and Pots), Serial Port, (Uart), and the Interrupt Control and Status Structure.

The 4 Audio Channels each have a DMA Pointer Register, Data Register, Period, (Frequency), Register and Volume Register. Each Channel has an on chip D to A, (Digital to Analog), Converter on the output. The 4 Channels are grouped into a Right and a Left Audio Output.

The Disk Controller has Registers for Data Read, Data Write and Control. It also contains a Precompensation Output Circuit a Data Separator Input Circuit with a Digital Phase Lock Loop.

The Serial Port UART included on PAULA contains Data Registers, Control Registers and Transmit, (TRN), and Receive, (REC), Registers.

The 4 Pot Ports are General Purpose I/O Ports. They have Counters for simple A to D, (Analog to Digital), Conversion of External Capacitor Charging which could be used for Analog Joystick Controllers.

The Audio, Disk and UART controllers all set their own Interrupt Status Register Bits. The Audio and Disk Controllers also go to the DMA Request Logic, (Remember: They are DMA Users), causing the DMAL Signal to request DMA Cycles from AGNUS.

SLIDE 12 -- DISK DMA

The Disk Controller uses only 1 DMA Channel with its own dedicated time slots for Data Transfer. A Block of Memory, up to 128K in length, can be read from or written to anywhere in the 512K of memory.

It has Adjustable Pre-compensation for writing disks, Digital PLL, (Phase Locked Loop), for reading disks and a Dual Speed Data Rate to allow most common FM, MFM, and GCR Formats to be utilized.

BASIC OPERATING THEORY
COMMODORE-AMIGA 1000 SYSTEM

SLIDE 13 -- AUDIO DMA

There are 4 Audio Controllers. Each is independent and uses 1 DMA Channel. (4 Total) Each Audio Controller fetches its data during a dedicated time slot within Horizontal Blanking.

Each Audio Controller can fetch a Digitized Waveform, up to 128K in length, from anywhere in the 512K of memory. Each has a Period, (Frequency), and Volume Control Registers. When each Audio Controller is done outputting the waveform, it automatically restarts itself at the beginning and issues a unique Interrupt.

Each Audio Channel has its own on-chip D to A, (Digital to Analog), Converter that has 8 Bits of Data combined with 6 Bits of Volume. The data is transferred under DMA Control but the Volume comes from a Preloaded Register.

Two of the Audio Channels drive the Left Stereo Output and the other two drive the Right Stereo Output. Channels can modulate each other in both Frequency and Volume which allows Vibrato and Whistle effects to be created.

DYNAMIC RAM REFRESH

The Refresh Controller uses only 1 DMA Channel with its own dedicated time slots. Addresses are placed on the Memory Address Bus during these slots in order to Refresh Dynamic RAM.

No Data Transfer takes place during Refresh so the Register Address Bus is used for Chip Synchronizing Codes during these time slots.

BASIC OPERATING THEORY

COMMODORE-AMIGA 1000 SYSTEM

The Amiga 1000 System actually utilizes two 16 Bit Bi-directional Data Buses and four Address Buses. The Data Bus connects the System RAM to all 3 Custom ICs and 68000 MPU through a Bi-Directional Tri-State Buffer.

DATA BUSES

1. One of the Data Buses is called the Micro Processor, (uP), or 68K Data Bus, (PD0-PD15), and is used to connect the 68000 MPU to the Expansion Bus, O/S RAM/ROM and the 8520 CIA Chips.
2. The other Data Bus is called the Display/uP Data Bus, (D0-D15), and is used to connect the System RAM directly to all three Custom Chips and also to the 68000 MPU through Bi-Directional Tri-State Buffers when no DMA is occurring.

ADDRESS BUSES

1. One Address Bus, (A1-A23), is a 23 Bit Bus and is generated either by the 68000 MPU or an External Bus Master.
2. One Address Bus is 8 Bits Multiplexed, (RA0-RA7), and is generated by either Agnus or the 68000 MPU. If this bus is generated by Agnus the multiplexing is done, (Hi to Lo Bit), if it is generated by the 68000 MPU it must be multiplexed before RAM.
3. One Address Bus is 18 Bits, (Multiplexed to 9 - DRA0-DRAS), generated by Agnus and is used to address the Dynamic RAMs during DMA or Refresh.
4. One Address Bus is 8 Bits, (RGAL-RGA8), generated by either Agnus or the 68000 and is used for Inner-Chip Communication. During a DMA Cycle, this Bus is Bi-Directional only on Agnus thus allowing Agnus' Co-Processor control. When no DMA is occurring the RGA Bus is driven by the Lo Address Bits of the 68000 MPU. This allows the 68000 MPU to Read or Write to the Custom Chips as though they were RAM.

This type of design allows the 68000 MPU to run without interference from DMA Cycles used for Display, Blitter etc.

BASIC OPERATING THEORY
COMMODORE-AMIGA 1000 SYSTEM

There are two basic types of RAM Cycles in the Amiga. One is called the 68K or Processor Access and the other is called the Agnus Access.

Agnus Access

When Agnus decides a DMA Cycle is required, it turns on DBR*, (Data Bus Request), on a falling edge of the Color Clock, CCK), also known as C1. DBR* is input to the PALEN PAL, (U5L), which enables the DAE*, (DMA Address Enable), signal. DAE will turn on with the next rising edge of C1 and stay on until the next falling edge of C3.

The DAE* Signal will turn on the outputs of a Tri-State Latch, (U2H), which drives the RAM Address Lines, (RA0-RA7). At this time the latch contains the Row Address loaded from Agnus DRA Lines.

The output of U8G then goes 'Low' which turns on RAS*, (Row Address Select), and the Row Address is clocked into the RAMs.

When RAS* turns on, the output of U9I, (DAC), goes 'High' and the Column Address, which is now on the DRA Lines is clocked into the Tri-State Latch, (U2H). The Column Address is clocked directly into the RAMs because the outputs of the latch are still enabled by DAE*.

The DAE* is also input to the PALCAS PAL, (U5M), which enables the UCEN and LCEN, (Upper and Lower CAS Enable), outputs. When both UCEN and LCEN are on, C1 goes low which enables two Decoders, (U1H and U1I). UCAS outputs, (U1H), and LCAS outputs, (U1I), will enable the CAS Inputs of the RAMs.

Agnus Memory Read Cycle

If Agnus decides this is to be a Read Cycle, it will hold the ARW*, (Agnus Read/Write) line 'High'. The ARW* signal is input to the PALCAS PAL, (U5M), which keeps the PAL from generating a RRW*, (RAM Read/Write), signal to the RAMs. This will cause the RAMs to drive the Data Bus and Data is output from the RAMs.

Agnus Memory Write Cycle

If Agnus decides this is to be a Write Cycle, it will output a 'LOW' signal on the ARW*, (Agnus Read/Write), line at the beginning of the cycle. The ARW* signal is input to the PALCAS PAL, (U5M), which will generate a RRW*, (RAM Read/Write), signal to the RAMs before CAS is turned on. This will cause Agnus to drive the Data Bus and Data is clocked into the RAMs.

Since the PALCAS PAL turns on the RRW* before CAS turns on, the RAMs can never turn on their outputs. This is necessary when using 64K x 4 RAMs.

When C1 goes 'High' again, the cycle is complete and Agnus is ready for a new cycle to begin.

BASIC OPERATING THEORY
COMMODORE-AMIGA 1000 SYSTEM

68K Access

When the 68000 MPU decides to do a Read Cycle, it turns on the AS*, (Address Strobe), output to the PALEN PAL, (U5L). When the address is in the right range for the RAMs and C1 is 'High' and C3 is 'Low', the PAL turns on the RE*, (RAM Enable), signal. This RE* signal enables two multiplexers, (U2I and U2J). These multiplexers drive A1 thru A8 into the RAM Array. The RAS*, (Row Address Select), output from U8G to the RAMs then goes 'Low' which clocks the Row Address.

The RE* signal is also input to the PALCAS PAL. Since this is a Read Cycle, the PAL generates a CDR*, (CPU Data Read), signal and also the UCEN, (Upper CAS Enable), and/or the LCEN, (Lower CAS Enable).

The CDR* signal from the PAL turns on the outputs of two latches, (U3H and U3J), which catch the Data coming out of the RAMs. Since the RAM Cycle ends before the 68000 MPU's Bus Cycle is over, the latches must hold this data.

UCEN turns on only if UDS*, (Upper Data Strobe), from the 68000 is also on and LCEN turns on only if LDS*, (Lower Data Strobe), from the 68000 is on. This is done to generate separate CAS signals for doing Byte Writes.

When C1 goes low, whichever CAS is enabled will turn on causing the RAMs to output Data on the Data Bus. Because the CDR* Signal from the PAL is still keeping the outputs of the latches on, the Data coming from the RAMs is caught and latched. With C1 still 'Low', C4 goes 'Low' which shuts the latches and saves the RAM Data. The RAM Data is then driven onto the 68000 Bus.

This Data will stay on the Bus until the 68000 releases both UDS* and LDS*, at which time CDR* is no longer active.

SECTION ONE

AMIGA 1000 CUSTOM DEMO

VERSION C-1.1

OPERATION PROCEDURES

VERSION C-1.1 CUSTOM DEMO DISKETTE

OPERATION PROCEDURES

The Version C-1.1 Custom Demo Diskette has proved to be a very effective tool to isolate Custom IC failures on the Amiga 1000 System. The listed instructions will provide a step by step guide to using this diskette.

```
*****  
*** USE THE TROUBLESHOOTING PROCEDURES CONTAINED IN THE AMIGA 1000 ***  
*** ASSEMBLY LEVEL REPAIR SECTION OF THE AMIGA SERVICE MANUAL TO ***  
*** ENSURE THAT THE PCB IS THE FAILED ASSEMBLY. ***  
***  
*** PLEASE REFER TO SECTION 3 FOR EXPLANATIONS OF COMMONLY USED TERMS ***  
*****
```

- Step 1 Before applying power to the system, connect an External Drive, 256K Ram Expander and Mouse Controller.
- Step 2 After System power up the Kickstart Prompt will be displayed.
At this Prompt, insert the Version 1.1 Kickstart Diskette into the Internal Drive.
NOTE: If the Kickstart Prompt is not displayed refer to Section 2
- Step 3 When Kickstart is loaded the Workbench Prompt will be displayed.
At this Prompt, remove the Kickstart Diskette from the Internal Drive and insert the Custom Demo Diskette.
NOTE: If the Workbench Prompt is not displayed or the Kickstart Prompt displays again, refer to Section 2.
- Step 4 When the Workbench Screen is displayed, Activate the Custom Demo ICON.
NOTE: If the ICON cannot be Activated or the Workbench Screen does not display correctly, refer to Section 2.
- Step 5 When the Custom Demo ICON Window is displayed, Activate the H.A.M. Demo ICON. The H.A.M. Demo will display all 4096 Colors that the System is capable of producing.
NOTE: If the Demo displays correctly, close the window by selecting the Gadget in the upper left hand corner.
NOTE: If the H.A.M. Demo does not display or displays incorrectly, refer to Section 2.
- Step 6 Activate the Molly Demo ICON. The Molly Demo displays colored balls which should move smoothly and continuously.
NOTE: If the Demo displays correctly, close the window by pulling down the screen until the Molly Window is visible, select the Gadget in the upper left hand corner then pull the Workbench Screen back up to the top of the display.
NOTE: If the Molly Demo does not display or displays incorrectly, refer to Section 2.

VERSION C-1.1 CUSTOM DEMO DISKETTE

OPERATION PROCEDURES

- Step 7 Activate the Fields Demo ICON. The Fields Demo displays 3-dimensional translucent, randomly shaped polygons of different colors rotating on the screen.
NOTE: If the Demo displays correctly, close the window by pulling down the screen until the Fields Window is visible, select the Gadget in the upper left hand corner then pull the Workbench Screen back up to the top of the display.
NOTE: If the Fields Demo does not display or displays incorrectly, refer to Section 2.
- Step 8 Activate the Colorful Demo ICON. The Colorful Demo displays 256 colors, changing red shades from top to bottom and blue shades from left to right.
NOTE: If the Demo displays correctly, close the window by selecting the Gadget in the upper left hand corner.
NOTE: If the Colorful Demo does not display or displays incorrectly, refer to Section 2.
- Step 9 Activate the Amiga 3D Demo ICON. The Amiga 3D Demo displays a 3-Dimensional Amiga Logo rotating on the screen.
NOTE: If the Demo displays correctly, close the window by selecting the Gadget in the upper left hand corner.
** The Gadget will not be visible on the screen
NOTE: If the Amiga 3D Demo does not display or displays incorrectly, refer to Section 2.
- Step 10 Activate the Boing! Demo ICON. The Boing! Demo displays a bouncing ball with a shadow. To view the Demo, pull the Workbench Screen down approximately 2/3 of the way and wait for the ball to fully develop. Click the right mouse button to speed up the Demo and the left button to slow it down. The System Audio is tested using this Demo.
NOTE: If the Demo is displayed correctly and both channels are producing audio, close the window by selecting the Gadget in the upper left hand corner then pull the Workbench Screen back up to the top of the display.
** The Gadget will not be visible on the screen.
NOTE: If the Boing! Demo does not display, displays incorrectly, both channels are not producing audio or audio is distorted, refer to Section 2.
- Step 11 Insert a Blank or Scratch Diskette in the External Drive. Move the mouse to the Custom Demo Icon, Press and hold down the left button, Move the mouse until it is over the DF1-ICON then release the button. When the Disk Copy window is displayed, select the Continue Option.
NOTE: When the Disk Copy is complete and the Custom Demo ICON Window is displayed, the Custom IC Tests are Complete.

*** IF ALL THE CUSTOM DEMOS OPERATE CORRECTLY IT MAY BE NECESSARY TO ***
*** CHECK THE SYSTEM BY DIRECTLY EMULATING THE CONDITIONS UNDER WHICH ***
*** THE CUSTOMER COMPLAINT SYMPTOMS OCCUR. ***

*** IF THE PCB FAILURE IS NOT THE RESULT OF ONE OF THE SOCKETED CUSTOM ***
*** IC'S PCB REPLACEMENT/EXCHANGE IS RECOMMENDED AT THIS TIME ***
)*****

SECTION TWO

AMIGA 1000 CUSTOM DEMO

VERSION C-1.1

COMMON SYMPTOMS AND FAILURES

VERSION C-1.1 CUSTOM DEMO DISKETTE

COMMON SYMPTOM AND FAILURE

POWER UP PROBLEMS

COMMON SYMPTOM	REPLACE	LOCATION
** Black Screen With White Bar is Displayed on System Power Up	8361 AGNUS	U4C
** Black Screen Display on System Power Up	8361 AGNUS	U4C
** Black Screen with Horizontal Dashes Displayed On System Power Up	8520 CIA	U6P
** Random Colored Horizontal Bars or Solid Colored Screen Displayed on System Power Up	8520 CIA	U6P
** Kickstart Prompt Does Not Display on System Power Up	8520 CIA 8520 CIA 8361 AGNUS	U6N U6P U4C

KICKSTART PROBLEMS

** Kickstart Prompt Displays but will not Load Kickstart	8520 CIA 8520 CIA	U6N U6P
** Kickstart Prompt Displays, Kickstart Seems to Load but Workbench Prompt does not display	8520 CIA	U6P
** Kickstart Prompt Displays, Internal Drive Knocks Against Stop Immediately or after Kickstart Starts Loading	8520 CIA	U6N

WORKBENCH PROBLEMS

** Workbench Screen Displays but the Custom Demo ICON cannot be Activated	8520 CIA	U6P
** Workbench Screen Displays Random Colored Pattern When Mouse Controller is Moved	8361 AGNUS	U4C
** Workbench Screen Title Bar Flashing	8364 PAULA	U4E
** Workbench Displays Disk Errors During Load e.g. - Disk Validation Error Not A DOS Disk	8364 PAULA	U4E

DEMO PROBLEMS

** Molly Demo Loads But Does Not Run	8520 CIA	U6N
** H.A.M. Demo Colors Flashing	8362 DENISE	U4A
** Colorful Demo Colors Flashing	8362 DENISE	U4A

DRIVE PROBLEMS

** External Drive Will Not Operate During Disk Copy	8520 CIA	U6N
---	----------	-----

SECTION THREE

AMIGA 1000 CUSTOM DEMO

VERSION C-1.1

COMMONLY USED TERMS

VERSION C-1.1 CUSTOM DEMO DISKETTE

COMMONLY USED TERMS

- ICON Symbol used to represent a selection within a window.
- GADGET Small Square Boxes located in the upper left and upper right hand corners of windows. The Gadget in the upper left hand corner is normally used to close windows while the Gadgets located in the upper right hand corner are normally used to change windows.
- ACTIVATE To Activate an ICON, use the mouse to position the pointer over the desired ICON. Tap the left mouse button two times without moving mouse. If the ICON is activated a cloud of "Z"s will appear as Data is being loaded.
- SELECT To Select a Gadget, (as in closing a window), use the mouse to position the pointer over the desired Gadget. Tap the left mouse button one time. If the Gadget is selected, the Demo Window will be cleared from the screen.
- PULL SCREEN To Pull a screen up or down use the mouse to position the pointer to the very top edge of the screen to be moved. Hold the left mouse button down while moving the pointer up or down as desired. The screen should move with the pointer. When the screen has been moved to the desired position, release the left mouse button and the screen will then stay at the present location.

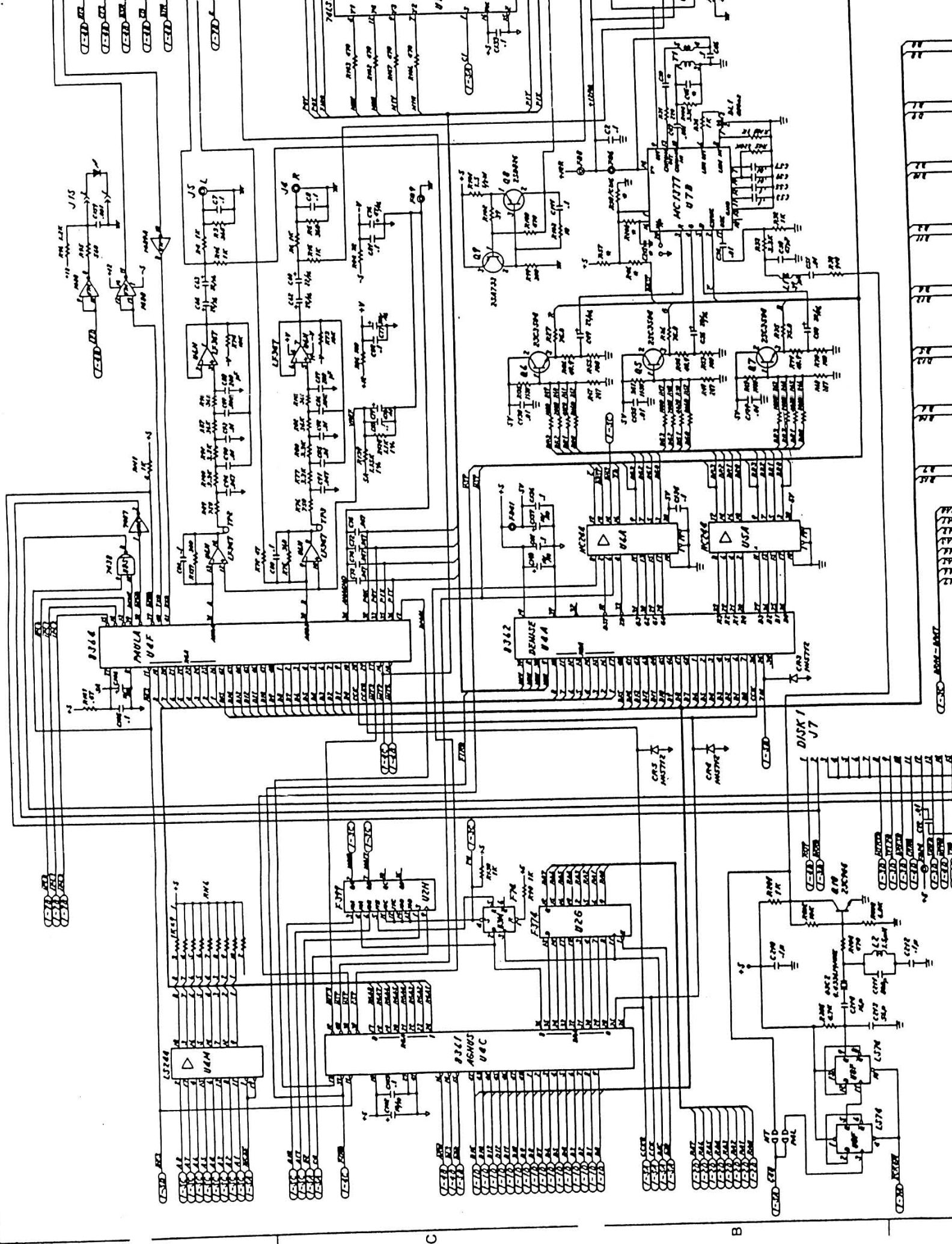

DISK 0 j10

WALL PARALLEL J8

J9 KBD

DISK 0

P2

J14 DC POWER

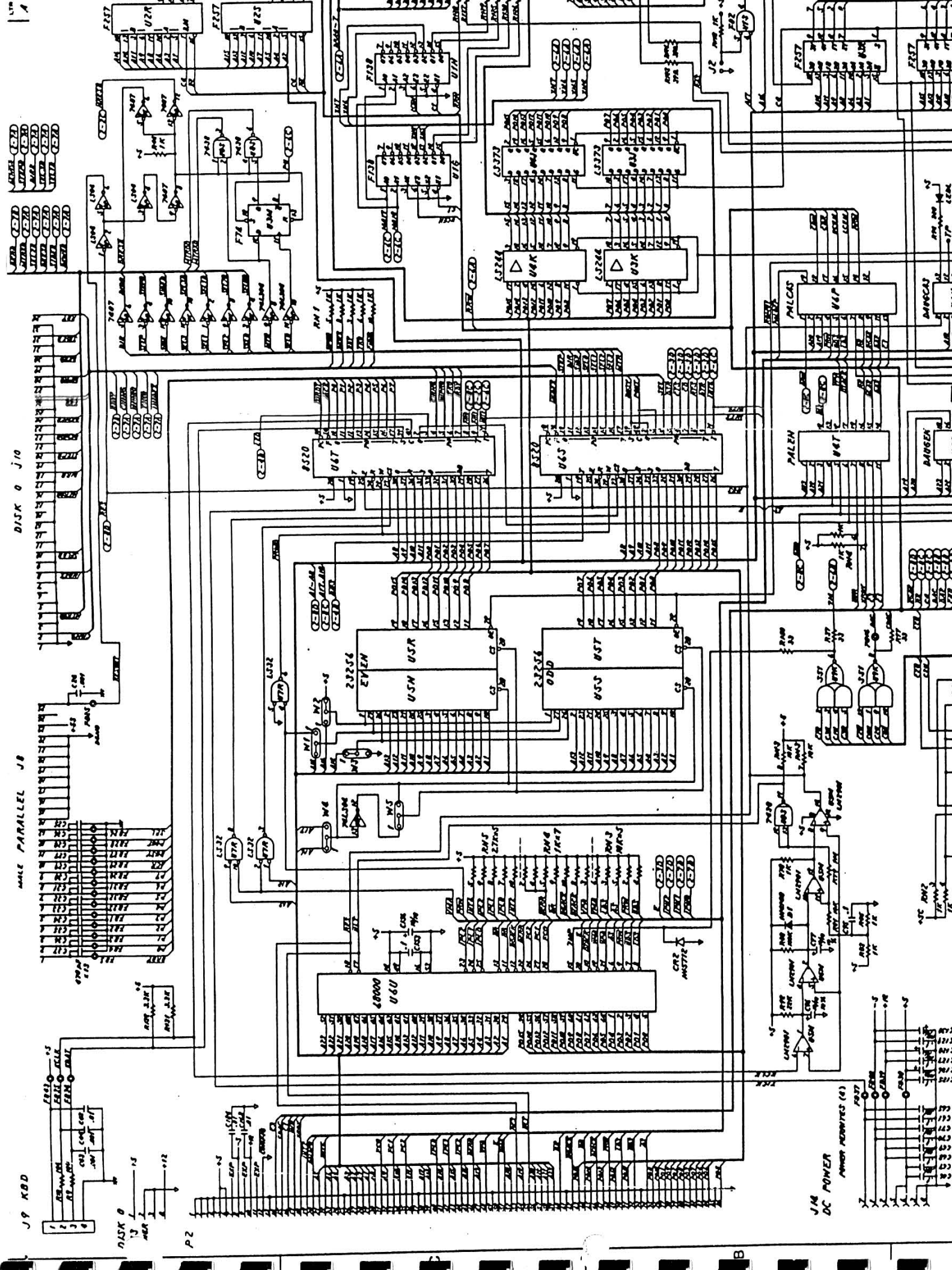

LTR	ZONE	PRODUCT	REVISED
A			
B			

PART NO.	APPROVED VENDOR	VENDOR PART NO.	LANGUAGE
327063-01	MITSUMI	R56 2144	ENGLISH
-02			BRITISH
-03		R56 2153	GERMAN
-04		R56 2152	FRENCH
327063-05	MITSUMI	R56 2154	ITALIAN

5. SHEET 2 IS D SIZE.
 4-3. (TA = 25°C)

	MIN	\bar{X}	MAX	UNIT
VF	IF = 10 mA	2.1	3.9	V
VR	VR = 3V	-	10	mA
IV	IF = 10 mA	3.6	12.0	mCd
ΔP	IF = 10 mA	6.5	-	nm
Δλ	IF = 10 mA	40	-	nm

4-2. PD: 60 mW
 IF: 20 mA
 VR: 3V (TA = 25°C)
 T_{OPR}: -25°C TO +85°C
 T_{STG}: -30°C TO +100°C

4-1. COLOR:

3-3. STORAGE TEMPERATURE RANGE: -40°C TO +65°C
 3-2. OPERATING TEMPERATURE RANGE: -5°C TO +55°C
 3-1. OPERATION LIFE: 10,000,000 THRES (12 VDC, 5 mA)

3. ENDURANCE SPECIFICATION

(1) KEY CAPS:

KEY TOP COLOR	BODY	LEGEND
ESC, DEL	CYCOLAC 33472	PANTONE 433C
OTHER KEY	CYCOLAC 33576	PANTONE 433C
SPACE KEY	CYCOLAC 33576	-
A . A	CYCOLAC 33576	PANTONE 200U

2-6. COLORS
 2-5. TEXTURE: ALL EXTERIOR SURFACES TO BE TEXTURED
 BEALON BK-105B OR EQUIV.
 (2) ARTWORK: TO BE PROVIDED BY COMMODORE.
 (1) STYLE: SUBLIMENTATION PRINTED, STEPPED
 SCULPTURED KEYS.

2-4. KEY CAP
 2-3. FULL TRAVEL: 4 ± 0.5 mm
 2-2. OPERATING POINT:

OFF REGION
INTERMEDIATE REGION
ON REGION

(2) MAXIMUM FORCE: 60 ± 20 GR (EXCEPT SP KEY,
 RETURN KEY & SHIFT KEY)
 (1) OPERATING FORCE: 50 GR TYPICAL

